

TECHNICAL BULLETIN

FOR

**TACTICAL VEHICLES:
INSTALLATION OF
UNIVERSAL TIEDOWN ANCHORS**

Approved for public release; distribution is unlimited.

HEADQUARTERS, DEPARTMENT OF THE ARMY

8 JULY 1989

TACTICAL VEHICLES: INSTALLATION OF UNIVERSAL TIEDOWN ANCHORS

REPORTING ERRORS AND RECOMMENDING IMPROVEMENTS

You can help improve this bulletin. If you find any mistakes or if you know of a way to improve the procedures, please let us know. Mail your letter or DA Form 2028 (Recommended Changes to Publications and Blank Forms) direct to: Commander, U.S. Army Tank-Automotive Command, ATTN: AMSTA-MB, Warren, Michigan 48397-5000. A reply will be furnished to you.

Approved for public release; distribution is unlimited.

TABLE OF CONTENTS

SECTION I	GENERAL	PARAGRAPH	PAGE
	PURPOSE	1	1
	SCOPE	2	

* This bulletin supersedes TB 9-2300-280-30, 14 March 1974.

		PARAGRAPH	PAGE
SECTION II.	PROCEDURES		
	PARTS AND MATERIALS	3	
	INSTALLATION PROCEDURES	4	
APPENDIX A	REFERENCES		A-1
	SCOPE	A-1	A-1
	PUBLICATION INDEX	A-2	A-1
	OTHER PUBLICATIONS	A-3	A-1

SECTION I. INTRODUCTION

1. PURPOSE.

a. This bulletin provides Intermediate Direct Support (IDS) maintenance personnel with instructions for installing tiedown anchors onto certain cargo carrying support vehicles. The anchors will provide the necessary base required for securing nuclear loads and other sensitive cargo, and thereby prevent damage to the cargo which could otherwise result from load shifting. This bulletin is not an inspection guide for factory installed tiedown anchors.

b. This bulletin authorizes the field installation of tiedown anchors for specified vehicles (paragraph 2). The anchors, once installed, provide swiveling, recessed, readily accessible tiedown points for securing loads.

c. To secure the load, use approved ratchet-type tiedown strap assemblies (NSN 5340-01-089-4997). Each strap is fitted with a swivel-type snap hook at each end, which is inserted into the tiedown anchor eye. The tiedown anchor eye must rotate a minimum of 180°. The number of straps needed depends on the cargo being transported, not the number of anchors there are on the vehicle. Refer to the appropriate weapon system technical manual or Army Materiel Command (AMC) approved outloading drawings to determine the number of straps required for transporting the particular cargo you are carrying. Use those technical manuals as requisitioning authority when ordering straps. Also, refer to those manuals or drawings for specific procedures to be used in securing nuclear loads or other sensitive cargo.

2. SCOPE.

a. Tiedown anchors are applied to the following vehicles:

- (1) Truck, Cargo: 2-1/2-ton, M35, M35A1, M35A2, M35A2C, M36, M36A1, M36A2, M36A2C, M36C.
- (2) Truck, Dump: 2-1/2-ton, M342, M342A1, M342A2.
- (3) Truck, Cargo: 5-ton, M54, M54A1, M54A1C, M54A2, M54A2C, M55, M55A1, M55A2, M813, M813A1, M814.
- (4) Truck, Dump: 5-ton, M51, M51A1, M51A2, M817.
- (5) Trailer, Cargo: 1/4-ton, M416, M416A1.
- (6) Trailer, Cargo: 3/4-ton, M101, M101A1, M101A2.
- (7) Trailer, Cargo: 1 1/2-ton, M105A1, M105A2, M332

b. The vehicles listed in paragraph 2a above should be modified only if they support the following weapon systems:

- (1) Pershing Missile System
- (2) Pershing II Missile System
- (3) Nike-Hercules Missile System
- (4) Honest John Missile System
- (5) 8-inch Howitzer-Towed and Self-Propelled

TB 9-2300-280-30

- (6) 155 MM Howitzer
- (7) Target Drone
- (8) Atomic Demolition Munitions
- (9) Hawk Missile System
- (10) Lance Missile System
- (11) AN/TSQ-73 system

c. The MI 27 trailer (Semitrailer Stake, 12-ton) is intentionally exempt from installation procedures of this publication. Tiedown anchors for this vehicle have been independently developed and are available under NSN 2510-00-134-1130. Instructions are enclosed in the tiedown container.

d. The M871 and M872 trailers (Semitrailer, tactical, dual purpose, breakbulk container transporter, 22 1/2-ton) are also intentionally exempt from installation procedures of this publication. Tiedown anchors for these vehicles have been independently developed and are available under NSN 2540-01-117-3043 (Fitting assembly deck) and NSN 2540-01-112-1732.

SECTION II. PROCEDURES

3. PARTS AND MATERIALS.

The tiedown anchors are provided in kit form. Apply anchors only in quantities listed in Table 1 and only in the locations specified in the applicable procedure. Parts and materials required to install the anchors can be requisitioned through normal supply channels.

Vehicle Model	Number of Tiedown Anchors
M35, M35A1 , M35A2, M35A2C	20
M36, M36A1 , M36A2, M36A2C, M36C	28
M51 , M51A1 , M51A2, M817	20
M54, M54A1 , M54A1C, M54A2, M54A2C, M813, M813A1	24
M55, M55A1 , M55A2, M814	36
M342, M342A1 , M342A2	16
M416, M416A1	10
M101, M101A1, M101A2,	10
M105A1 , M105A2	12
M332	12

Table 2. Tiedown Parts List

National Stock Number	Description	Unit of Measure	Quantity Authorized
2540-00-782-1467	Kit, Tiedown, P/N 10948047 (19207) Composed of:	EA	1
	Template, P/N 10944368 (19207)	EA	1
	Retainer, P/N 10945032-1 (19207)	EA	6
2510-00-489-8295	Eye, P/N 10945038 (19207)	EA	6
5306-00-225-9087	Bolt, Mach, Hex Head P/N MS90726-32 (96906)	EA	24
5310-00-880-7746	Nut, Plain, Hex P/N MS51968-5(96906)	EA	24
5310-00-081-4219	Washer, Flat, P/N MS27183-12 (96906)	EA	24

NOTE

Anerobic Sealant, NSN 8030-00-148-9833, P/N MIL-S-46163 (81349) is to be used on bolts, bolt holes, and nuts every time they are removed and replaced.

4. Installation Procedures.**NOTE**

To attach anchors requiring welding, arc weld using fillet welds approximately one (1) inch in length, covering at least eight (8) inches of the perimeter of the anchor retainer as shown in Figure 1. All welding is to be in accordance with TM 9-237.

a. Procedure for M36, M36A1, M36A2, M36A2C, M36C Trucks.

- (1) Remove and retain seven paulin lashing hooks from each side panel of cargo body. Discard 28 rivets.
- (2) Remove and retain two reflectors, four screws, and four nuts from each side panel of body.
- (3) Fabricate one 1/2 x 3 x 5-1/2 inch spacer from suitable scrap wood or metal.

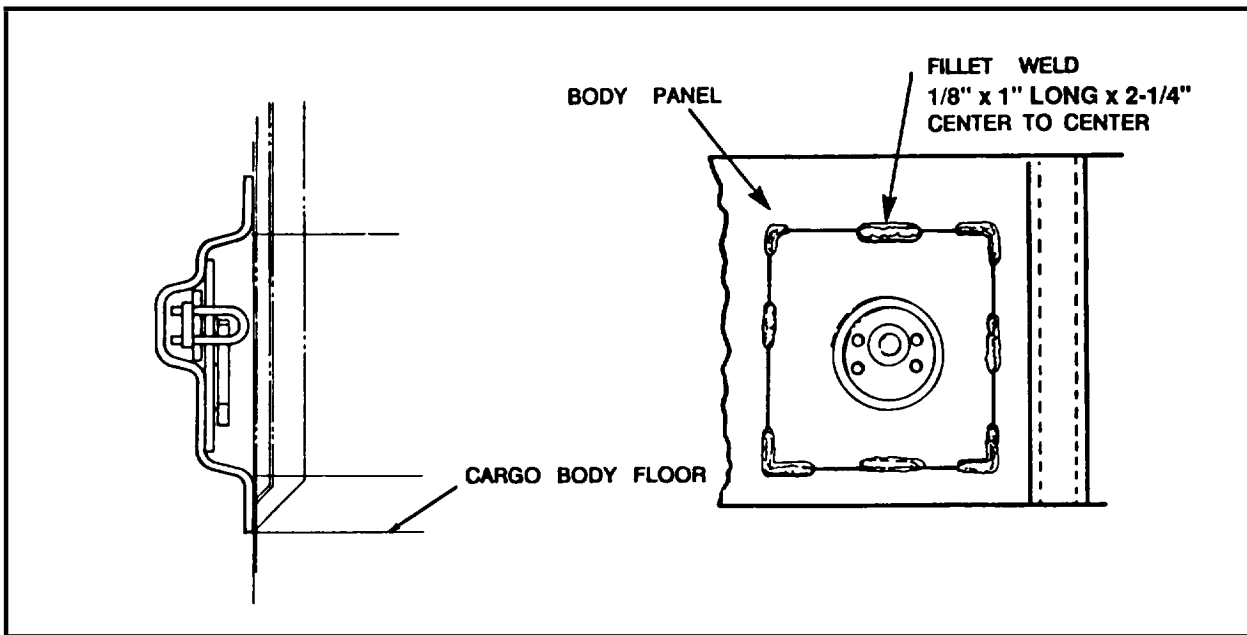

Figure 1. Anchor weldings to body panels

(4) Using template provided in kits and fabricated spacer (figure 2), scribe location of 12 anchors on left side, 12 on right side, two on front panel, and two on tailgate of body as shown in figures 3, 4, and 5.

(5) Using hole saw, cut out 28 anchor holes. Trim rough edges of holes.

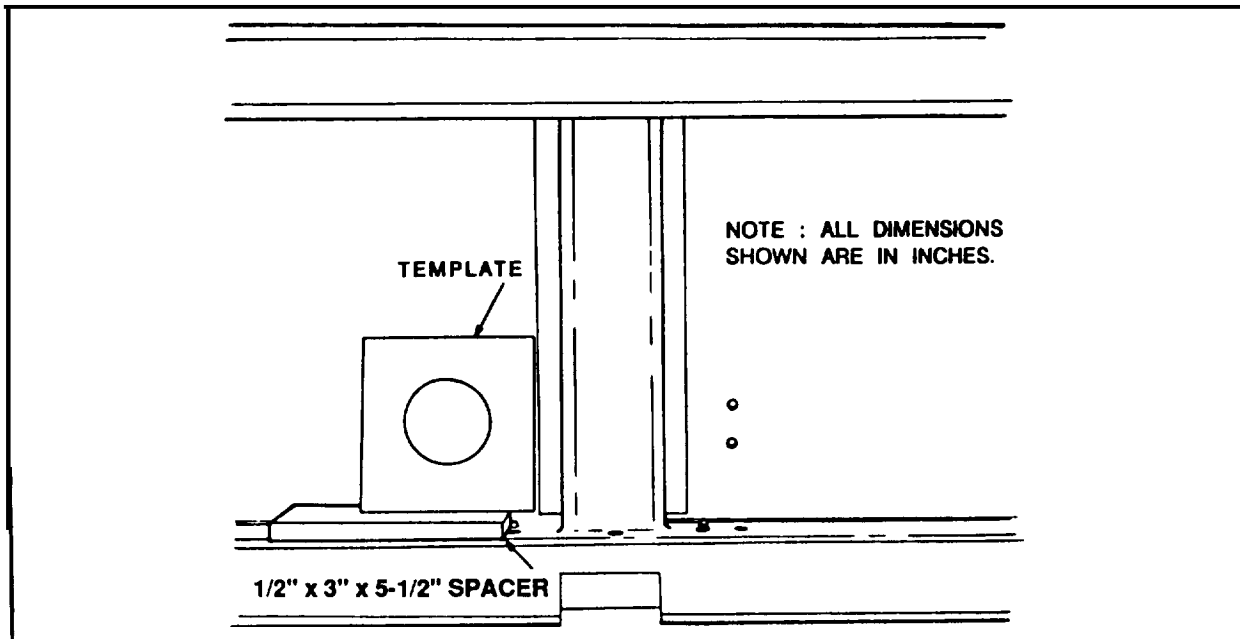

Figure 2. Template and spacer to locate tiedown anchor positions

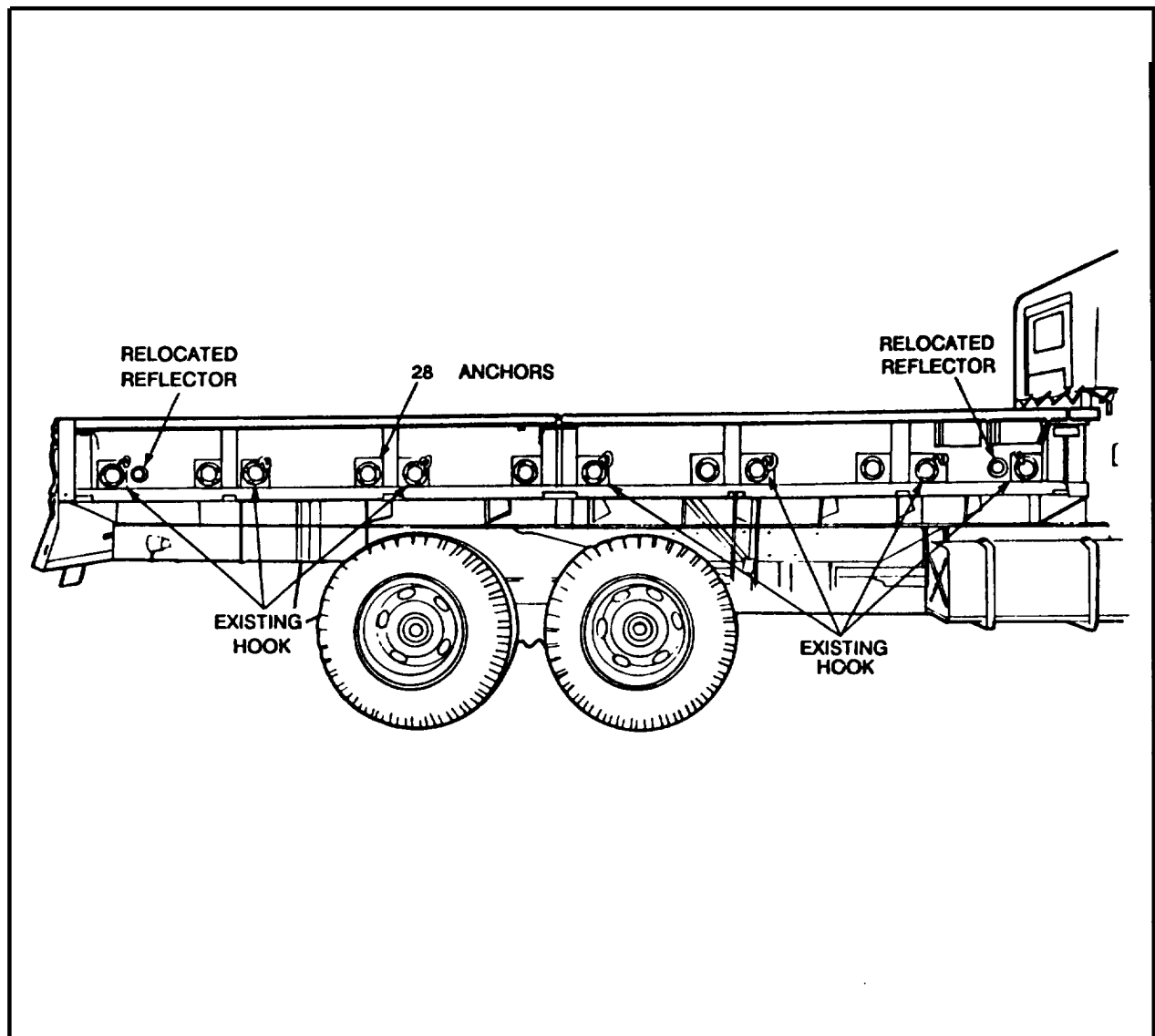

Figure 3. Location of anchors, reflectors, and hooks on right side of body on M36, M36A1, M36A2, M36 A2C, M36C

(6) Arc weld 28 anchors, using fillet welds. Welds are to be approximately 1/8 inch thick, 1 inch long and 2-1/4 inches center to center (figure 1).

(7) Position one lashing hook on each of seven anchors on left and on right side panels of body as shown in figures 3, 4, and 6.

(8) Using hook as template mark and drill two 1/4-inch diameter holes through anchor and body (figure 6).

(9) Install 14 hooks removed in step 1, using 28 rivets. If rivets are not available, use screws NSN 5305-00-988-1727 (MS 35206-283) and nut NSN 5310-00-088-1251 (MS 51922-1).

(10) Position two reflectors on each body side panel, 1/4-inch from anchor and with centerline of hole 3-3/8-inches from floor (figure 3,4, and 6).

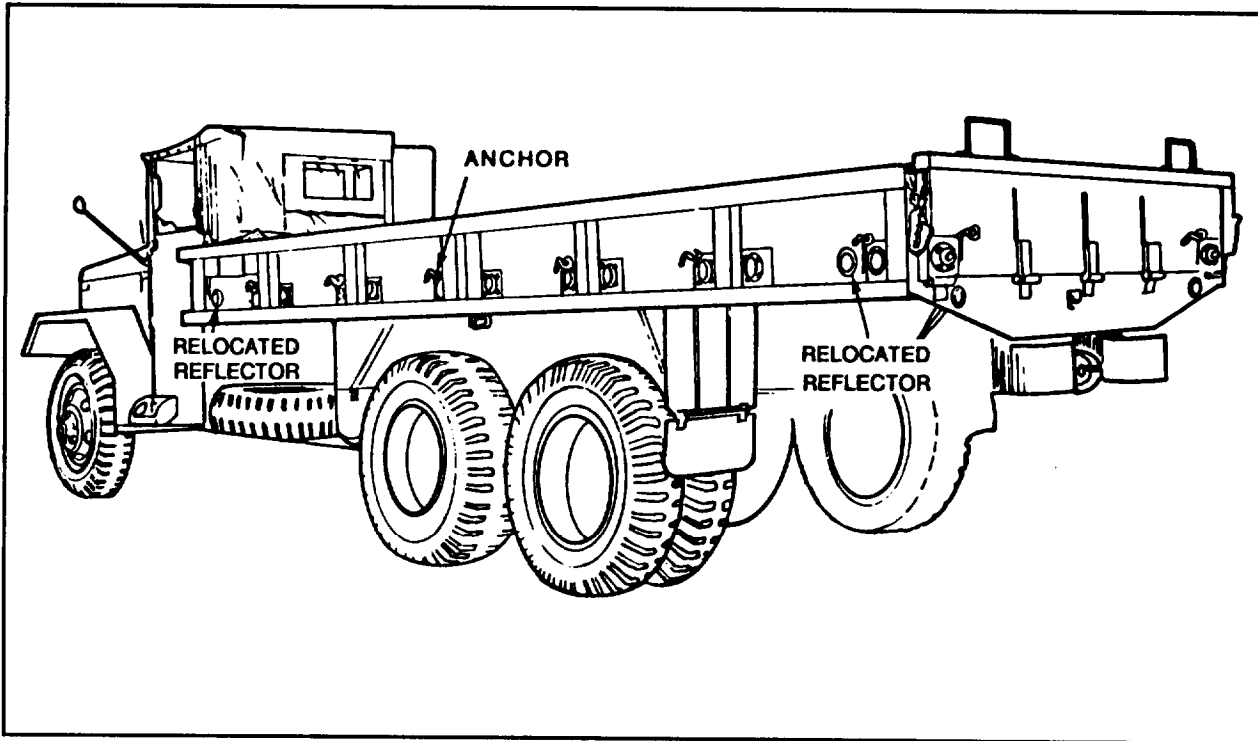

Figure 4. Location of anchors, reflectors, and hooks on left side and tailgate on M36, M36C, M36A1, M36A2, M36A2C trucks

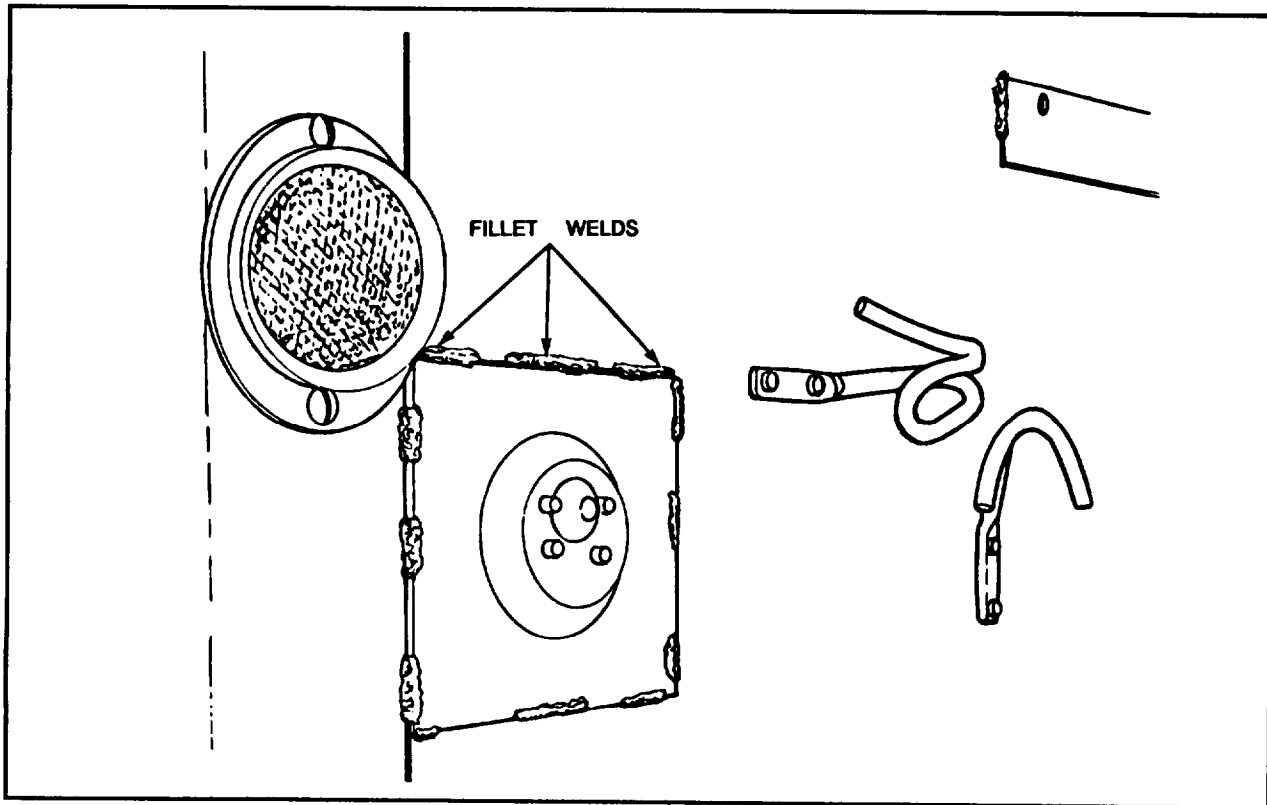

Figure 5. Anchors installed in front panel of cargo body on M36, M36C, M36A1, M36A2, M36A2C trucks

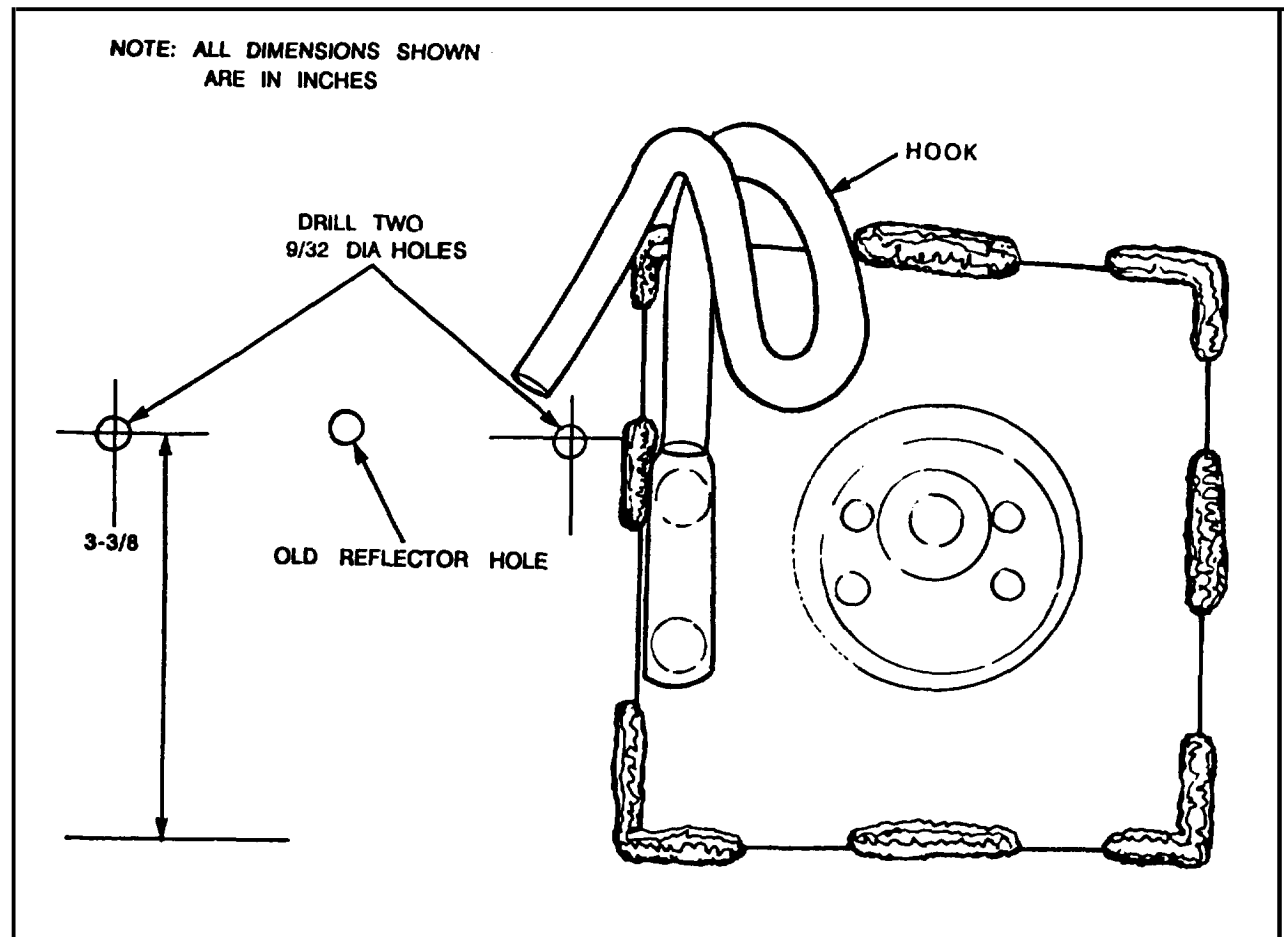

Figure 6. Location of reflector mounting holes

(11) Using reflector as template mark and drill two 9/32-inch diameter holes through body panel (figure 6).

(12) Install the four reflectors, using eight screws and nuts removed in step 2.

(13) Clean, prime, and paint in accordance with TM 43-0139.

b. Procedure for M35, M35A1, M35A2, and M35A2C Trucks.

(1) Remove and retain five paulin lashing hooks, two reflectors, four screws and four locknuts from each side panel of cargo body. Discard 20 rivets.

(2) Using template provided in kit, scribe location of eight anchors on left side, eight on right side, two on front, and two on rear panels of body, as shown in figures 7, 8, and 9.

(3) Cut holes matching the template. Trim rough edges and arc weld 20 anchors as shown in figure 4. For fillet welds, install hooks and reflectors, as in paragraph 4a, steps 9 through 13 (figure 5).

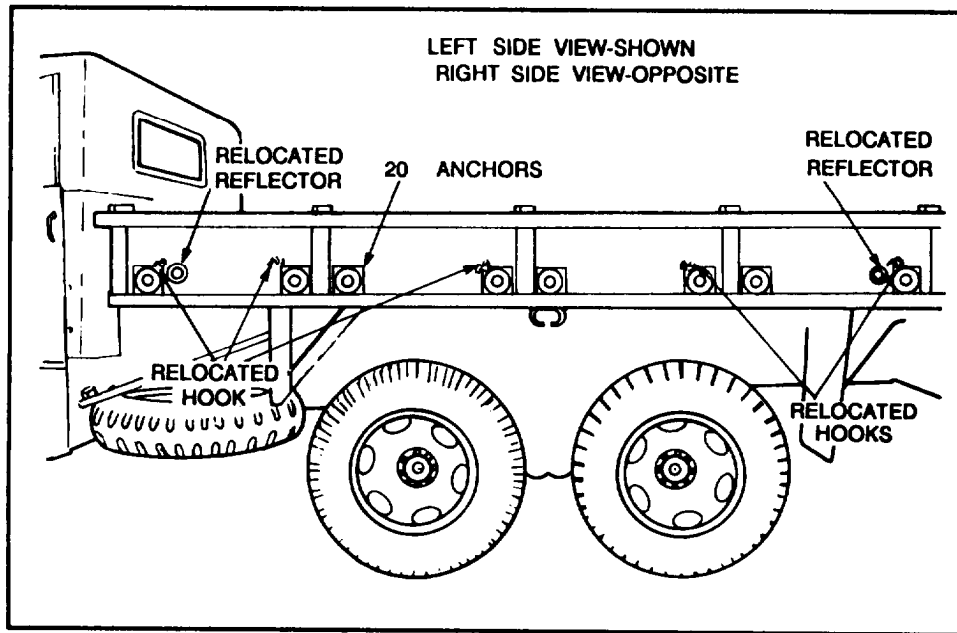

Figure 7. Location of anchors, hooks and reflectors on left side

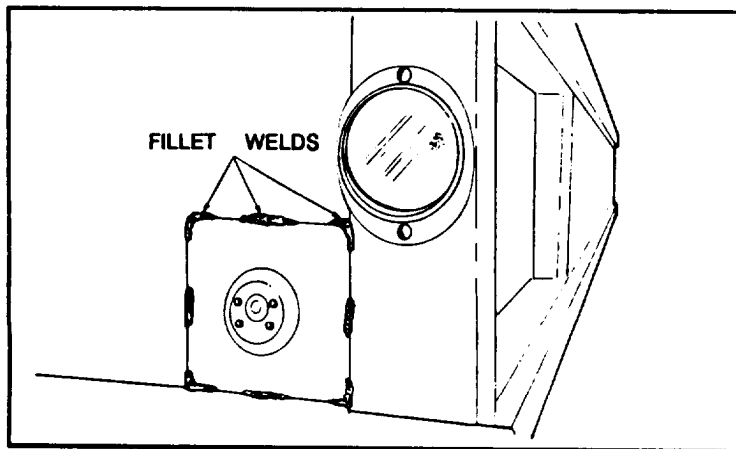

Figure 8. Anchor installed on front part of body

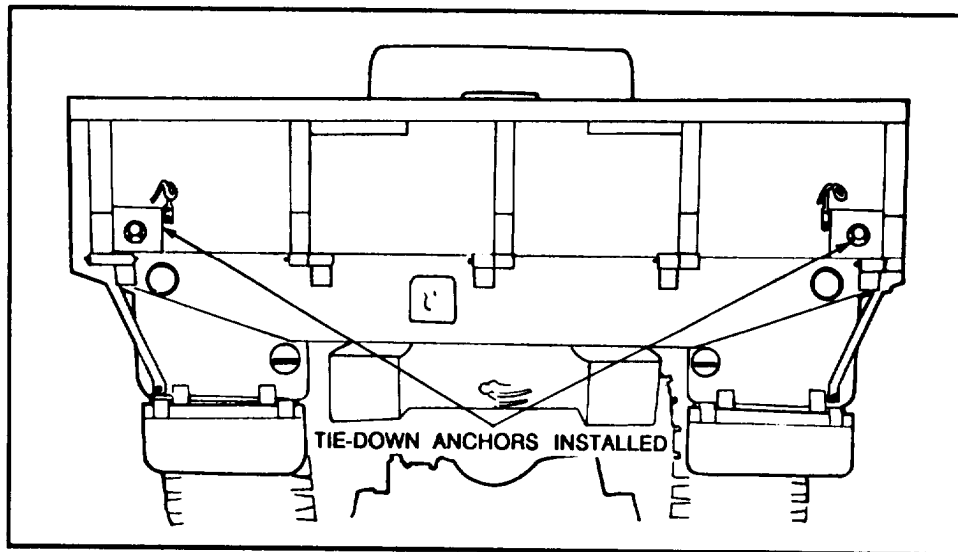

Figure 9. Location of anchors on tailgate

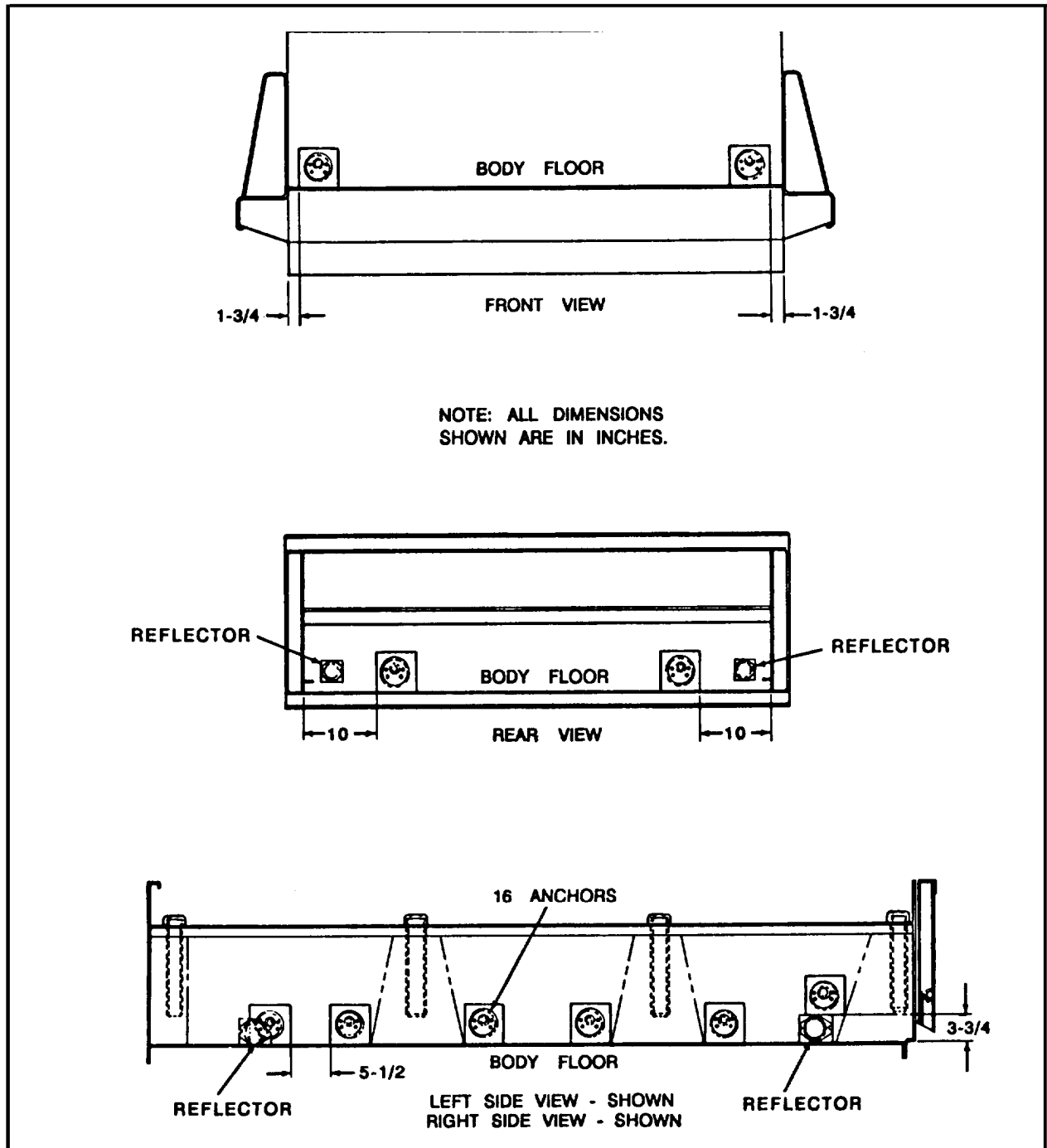

Figure 10. Location of anchors on M342, M342A1, M342A2 trucks

c. Procedure for M342, M342A1, and M342A2 Trucks.

(1) Using template provided in kit, scribe location of six anchors on left side, six on right side, two each on front panel and tailgate, as shown in figure 10.

(2) Cut holes matching the template. Trim rough edges and arc weld 16 anchors as shown in figure 1 for fillet welds.

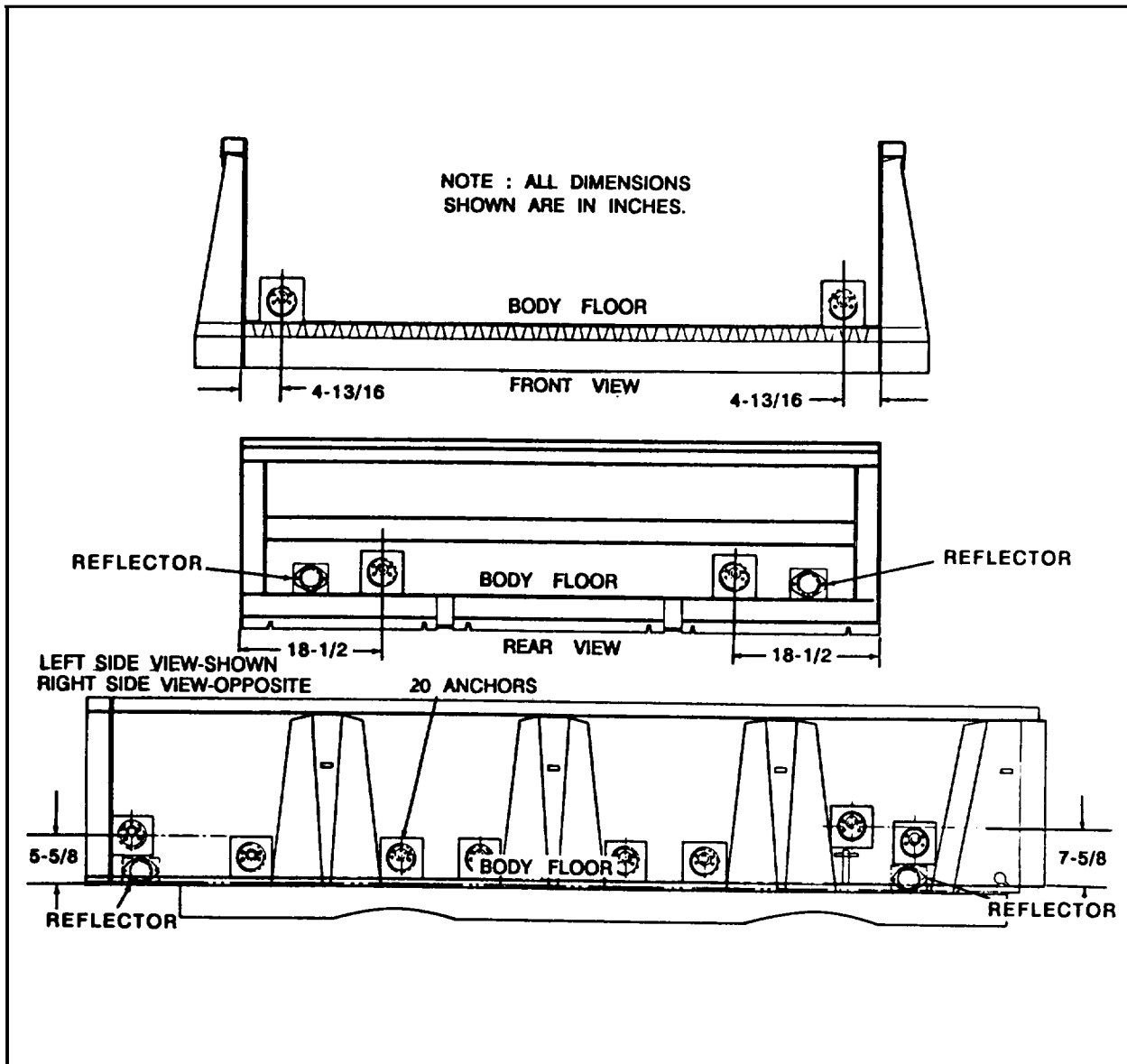

Figure 11. Location of anchors on M51, M51A1, M51A2, and M817 truck

(3) Clean, prime and paint in accordance with TM 43-0139.

d. Procedure for M51, M51A1, M51A2, M817 Trucks.

(1) Using template provided in kit, scribe location of eight anchors on left side, eight on right side, two on front panel and two on tailgate, as shown in figure 11.

(2) Cut holes using a hole saw, matching the template. Trim rough edges and arc weld 20 anchors as shown in figure 1, for fillet welds.

e. Procedure for M54, M54A1, M54A1C, M54A2, M54A2C, M813, M813A1 Trucks.

(1) Remove and retain five paulin lashing hooks, one reflector, two screws and two locknuts from each side panel of cargo body. Discard 20 rivets.

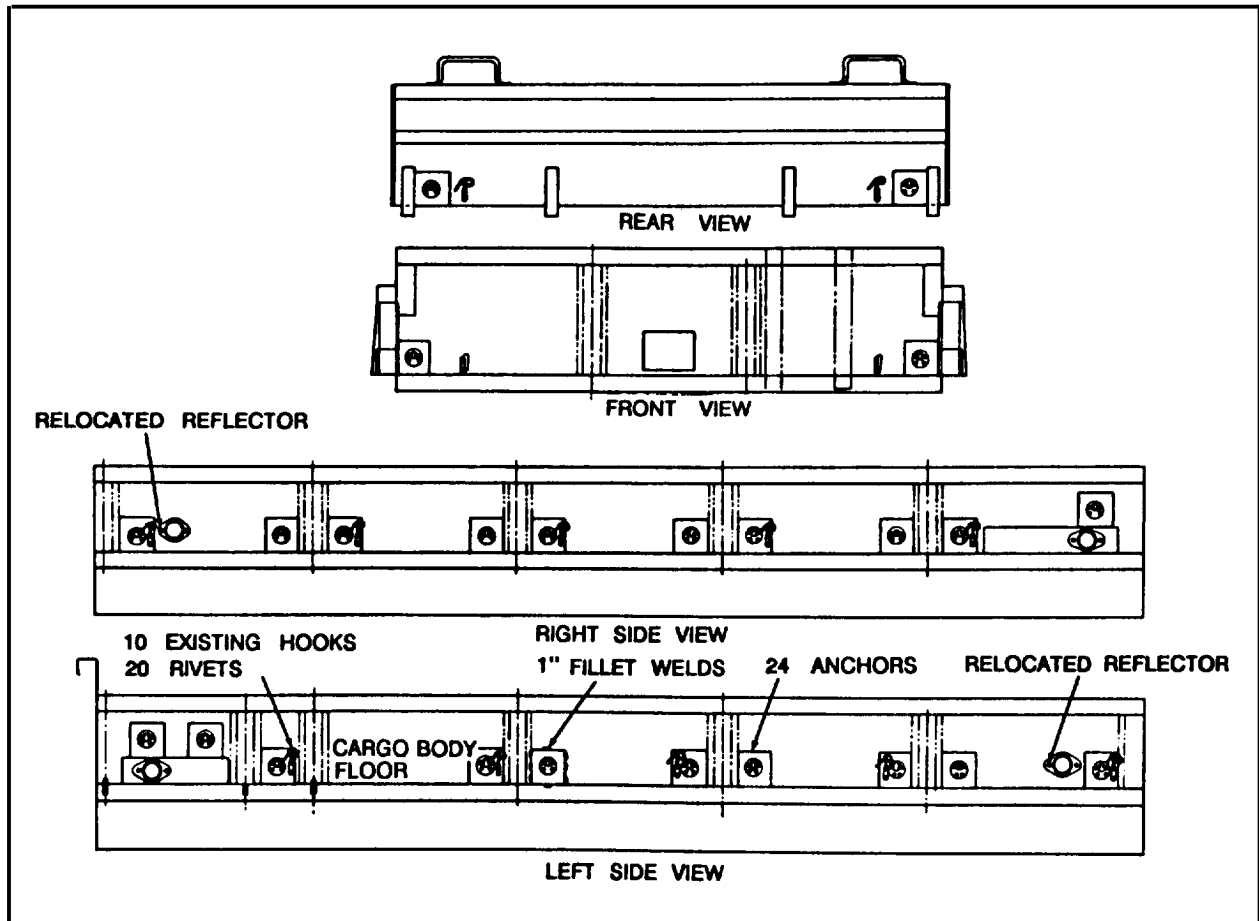

Figure 12. Location of anchors, hooks, and reflectors on M54, M54A1, M54A1C, M54A2, M54A2C, M813, M813A1 trucks

(2) Using template provided in kit and fabricated spacer (figure 2), scribe location of ten anchors on left side, ten on right side, two on front panel and two on tailgate, as shown in figure 12.

(3) Cut holes using a hole saw, matching the template. Trim rough edges and arc weld 24 anchors as shown in figure 1 for fillet welds. Install 10 hooks and two reflectors in paragraph 4a, steps (9) through (13).

f. Procedure for M55, M55A1, M55A2, M814 Trucks.

(1) Remove and retain seven paulin lashing hooks, one reflector, two screws and two locknuts from each side panel of cargo body. Discard 28 lashing hook screws and nuts.

(2) Using template provided in kit and fabricated spacer (figure 2), scribe location of sixteen anchors on left side, sixteen on right side, two on front, and two on rear panels of body (figure 13).

NOTE

Center template between bow storage bracket holes, as shown in figure 14.

(3) Cut holes matching the template. Trim rough edges and arc weld 36 anchors as shown 1 for fillet welds. Install 14 hooks and two reflectors as shown in paragraph 1-4, (9) through (13).

g. Procedure for M105A1 and M105A2 Trailers.

(1) Remove two rear (red) and four side (amber) reflectors from cargo body. Retain red reflectors, attaching nuts and screws. Discard amber reflectors.

(2) Using template provided in kit, scribe location of four anchors on left side, four on right side (figure 15), two on front panel (figure 16), and two on tailgate (figure 17).

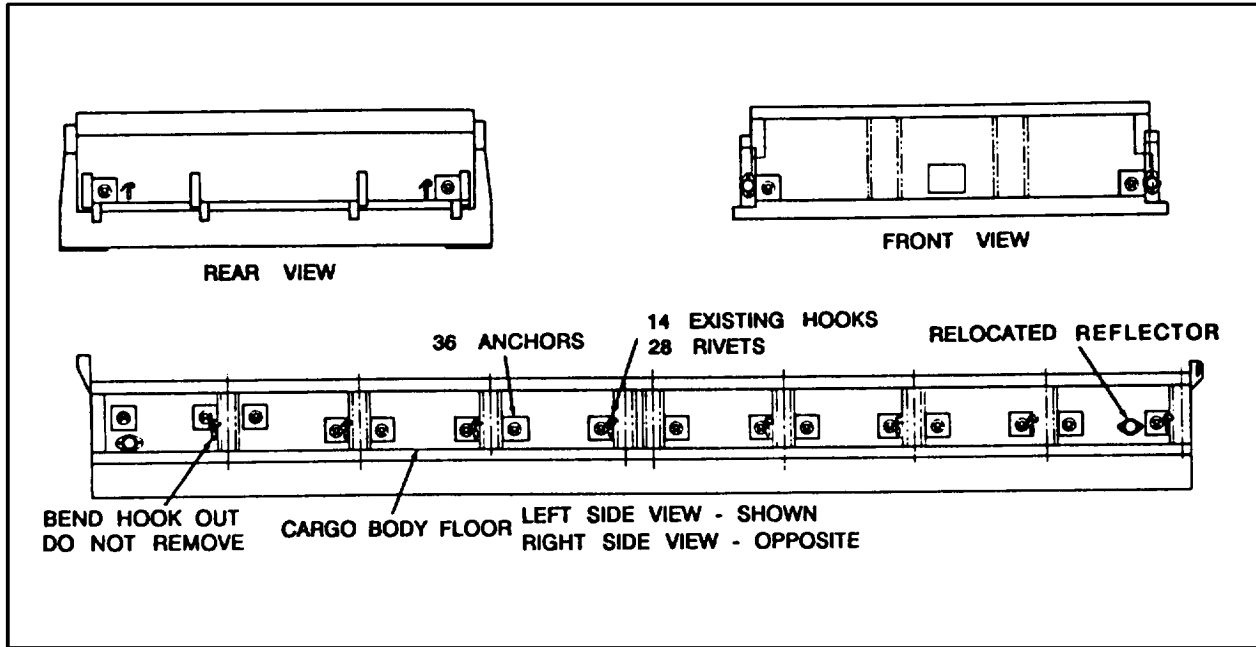

Figure 13. Location of anchors, hooks, and reflectors on M55, M55A1, M55A2 and M814 trucks

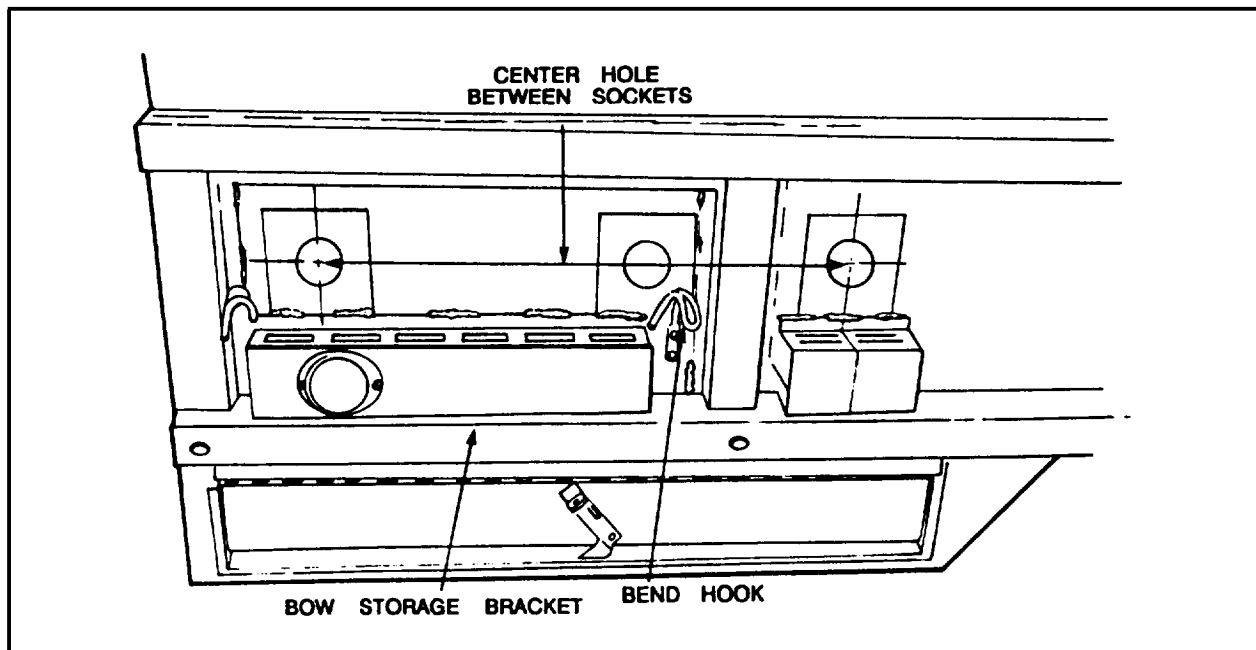

Figure 14. Location of anchors above bow storage brackets on M55, M55AC, and M814 trucks

(3) Using hole saw, cut out 12 anchor holes. Trim rough edges of holes.

NOTE

Do not remove lashing hooks.

(4) To install anchor near lashing hook, notch anchor plate as necessary. Exercise care not to damage disked section on outside (rear) of anchor.

(5) Arc weld 12 anchors, using fillet welds (figure 1).

(6) Locate reflectors remove in (1) as follows:

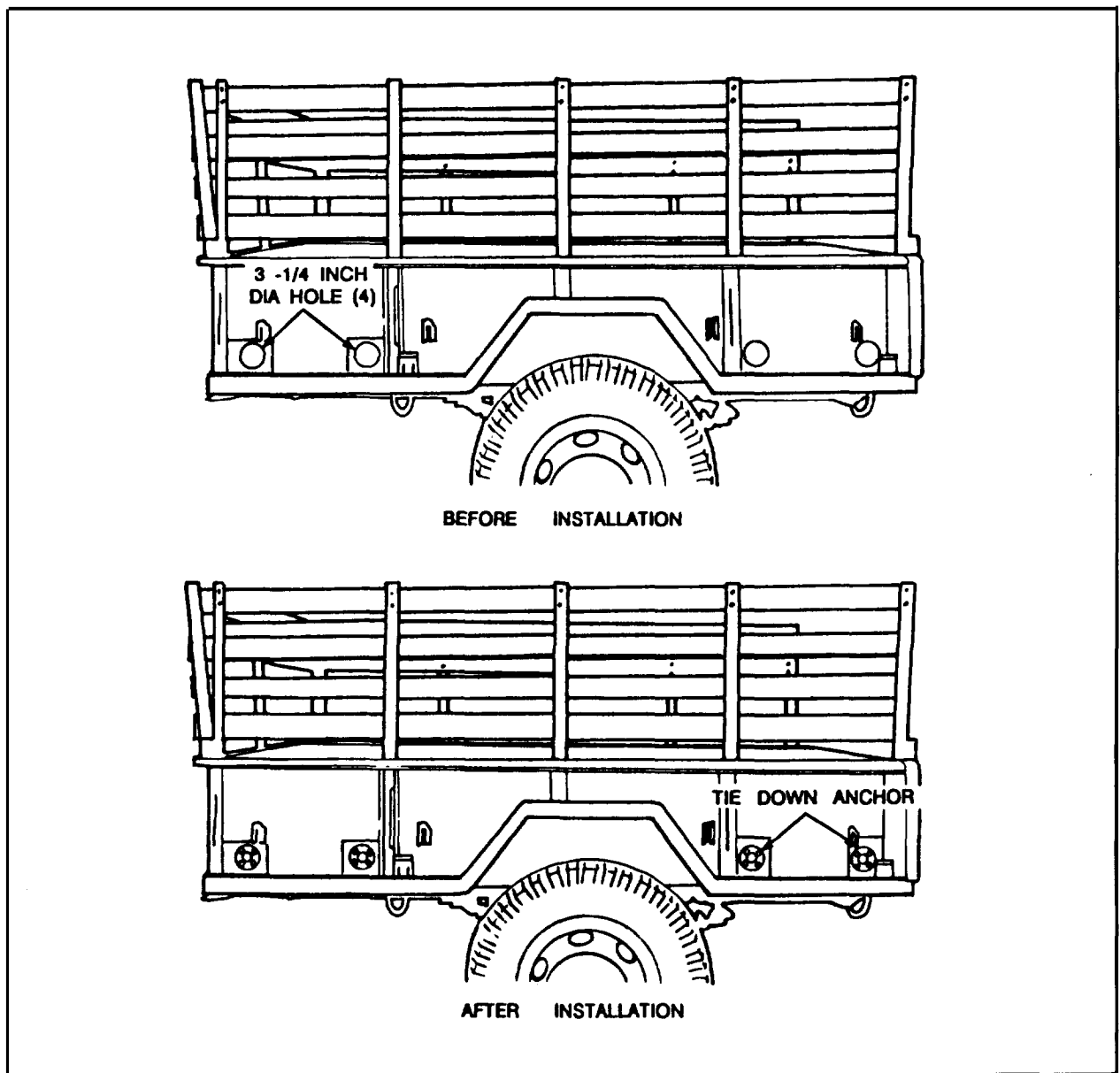

Figure 15. Installation of tiedown anchors on trailer side panel

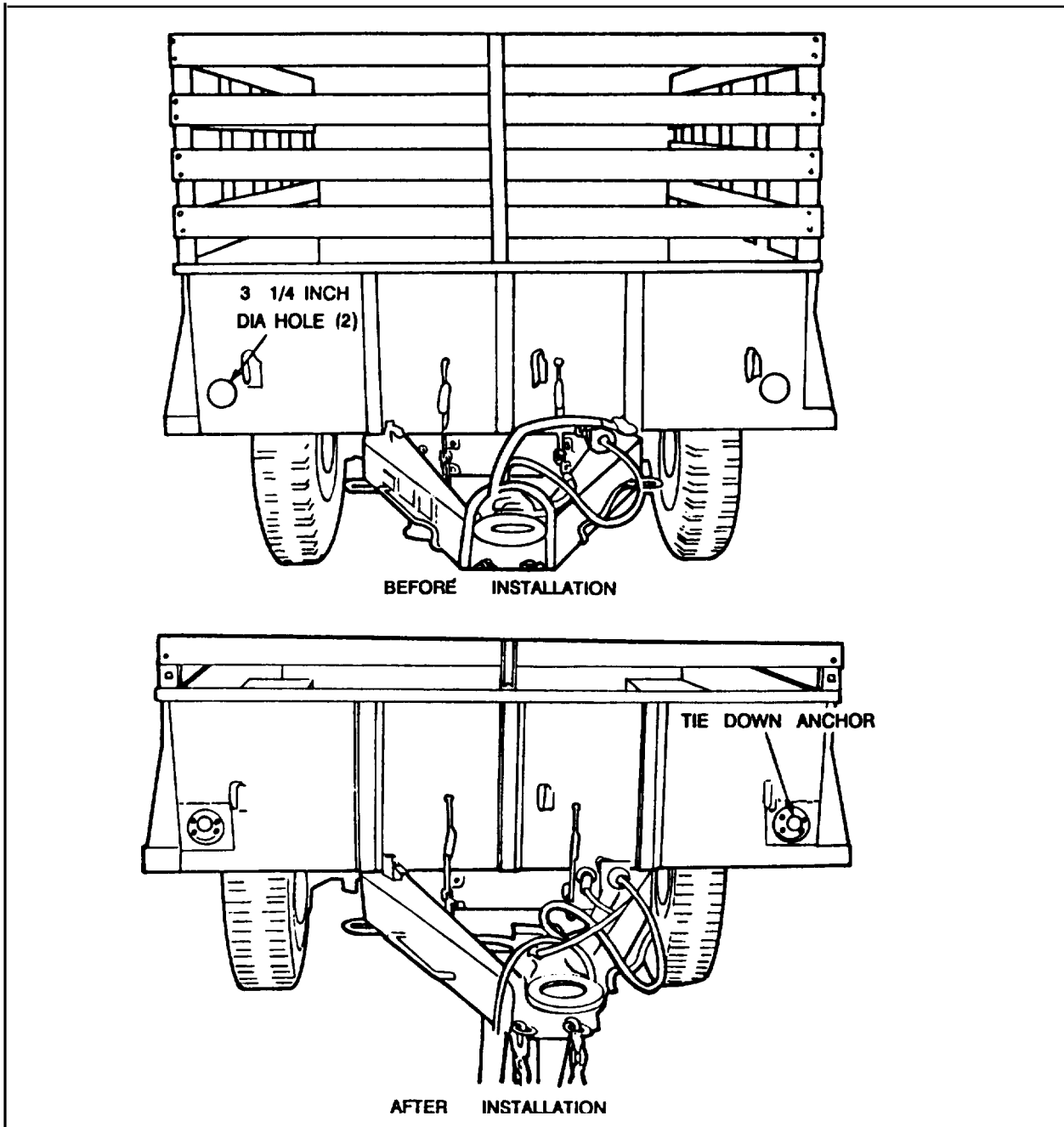

Figure 16. Installation of tiedown anchors on trailer front panel

(a) Position reflectors on tailgate panel 3/8-inch from bottom of panel and 1/2 inch from anchor plate. Mark location for 1/4-inch diameter holes from 1/4-inch diameter holes in reflector mounting holes.

(b) Drill two 1/4-inch diameter reflector mounting holes. Install reflector, using screws and nuts removed in (1) above.

(c) Clean, prime, and paint in accordance with TM 43-0139.

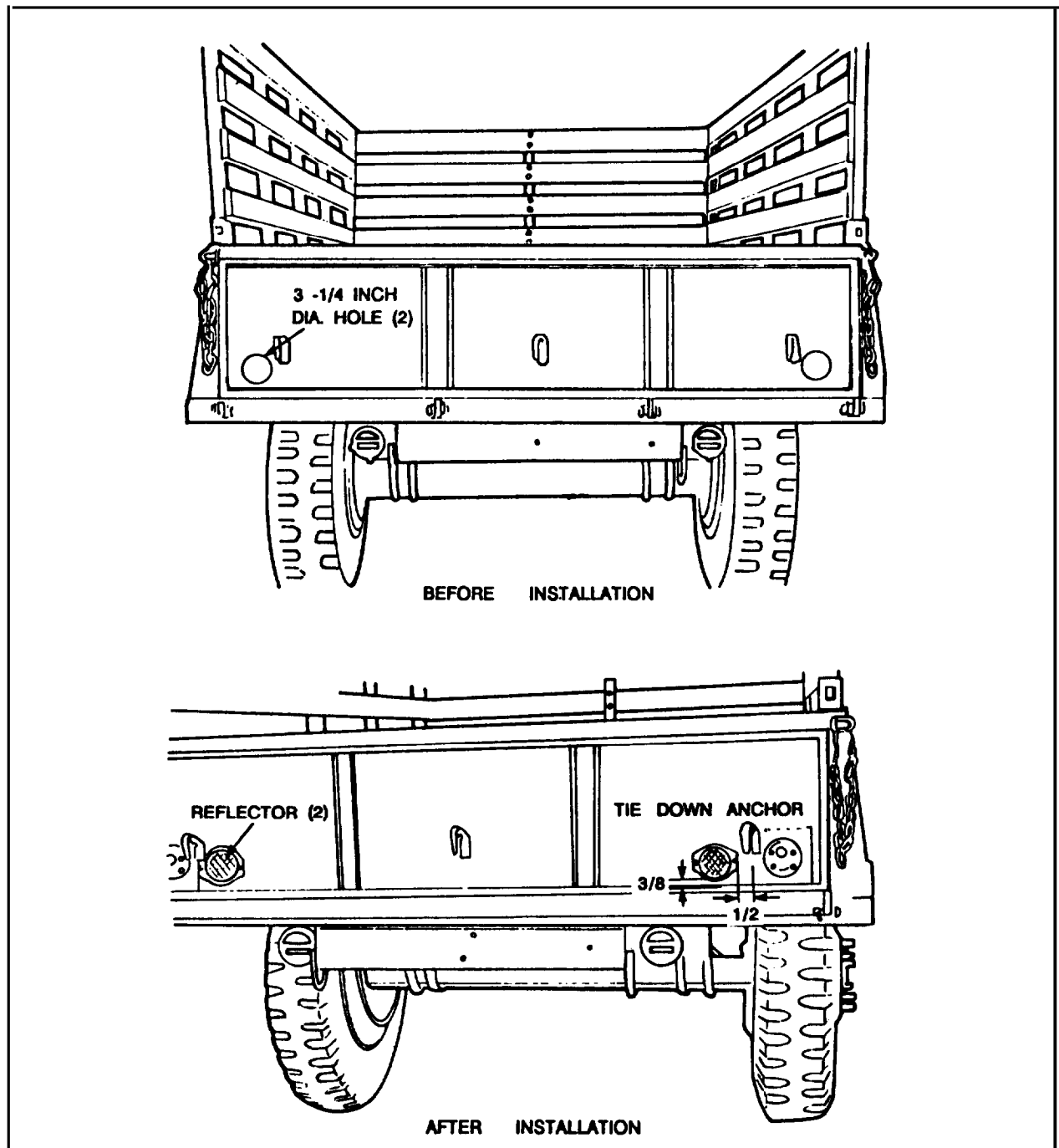

Figure 17. Installation of tiedown anchors and reflectors on trailer tailgate

h. Procedure for M101, M101A1, M101A2, M416, and M416A1 Trailers.

(1) Remove two red reflectors from each side panel of the cargo body and two red reflectors from the tailgate or rear panel. Retain reflectors and attaching screws, washers and nuts

(2) Using template provided in kit scribe location of the three anchors on left side, three on right side (figure 18 & 19) two on front panel and two on tailgate or rear panel.

(3) Using hole saw, cut out 10 anchor holes. Trim rough edges of holes.

(4) If necessary, relocate paulin lashing hooks. To provide clearance for installation of reflectors, notch the anchor plate. Exercise care not to damage the disked section of the anchor plate.

(5) Arc weld ten anchors, using fillet welds as shown in figure 1.

(6) Position one reflector on each side panel of the cargo body and locate reflector mounting plate (figure 18). Drill two 1/4-inch holes in each side panel. Install reflectors, using screws, washers and nuts removed in (1) above.

(7) Position two reflectors on tailgate and locate reflector mounting holes (figure 19). Drill four 1/4-inch diameter holes in tailgate. Install reflectors using screws, washers, and nuts removed in (1) above.

(8) Clean, prime, and paint in accordance with TM 43-0139.

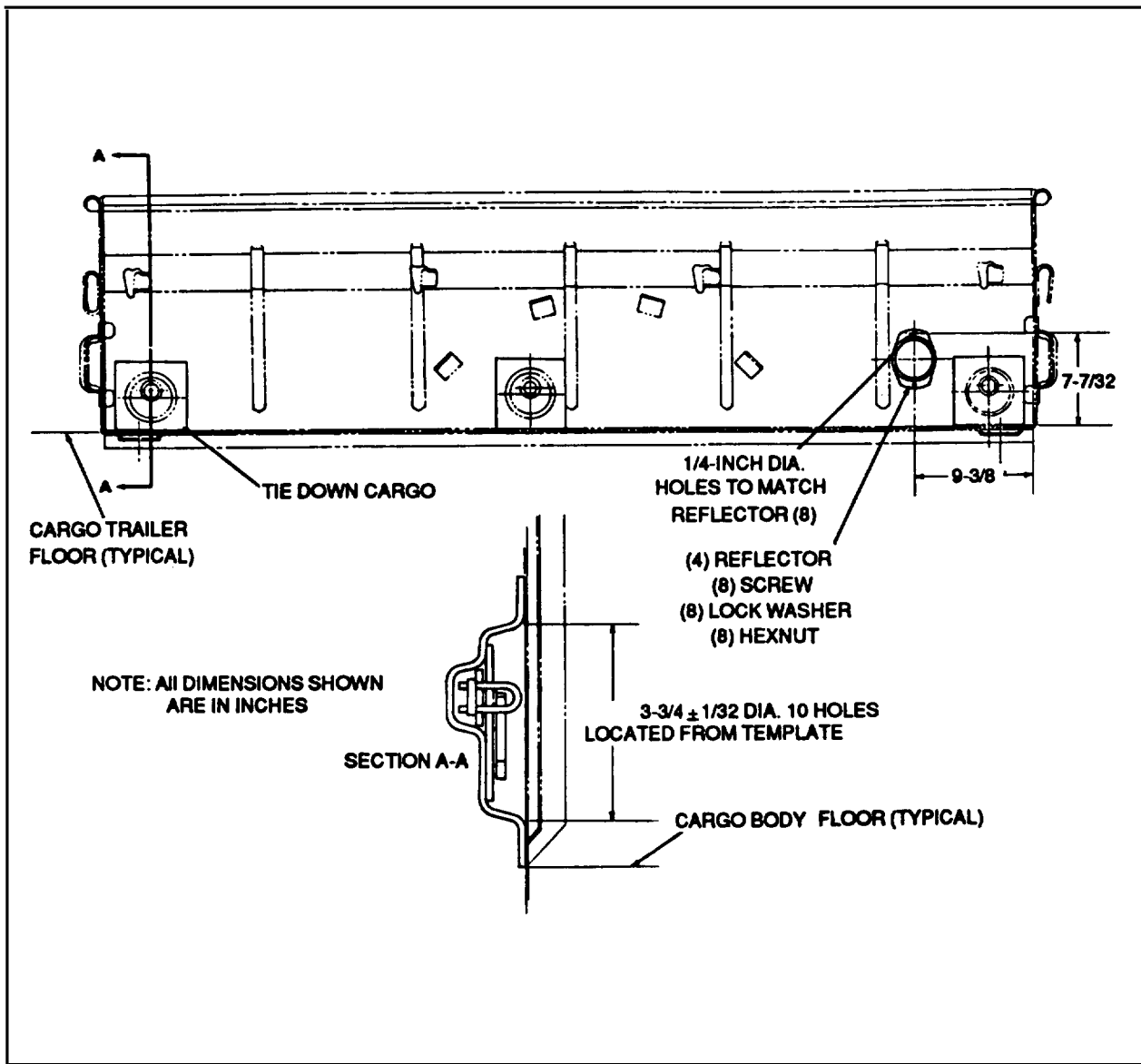

Figure 18. Anchor location and reflector mounting dimensions-side panel

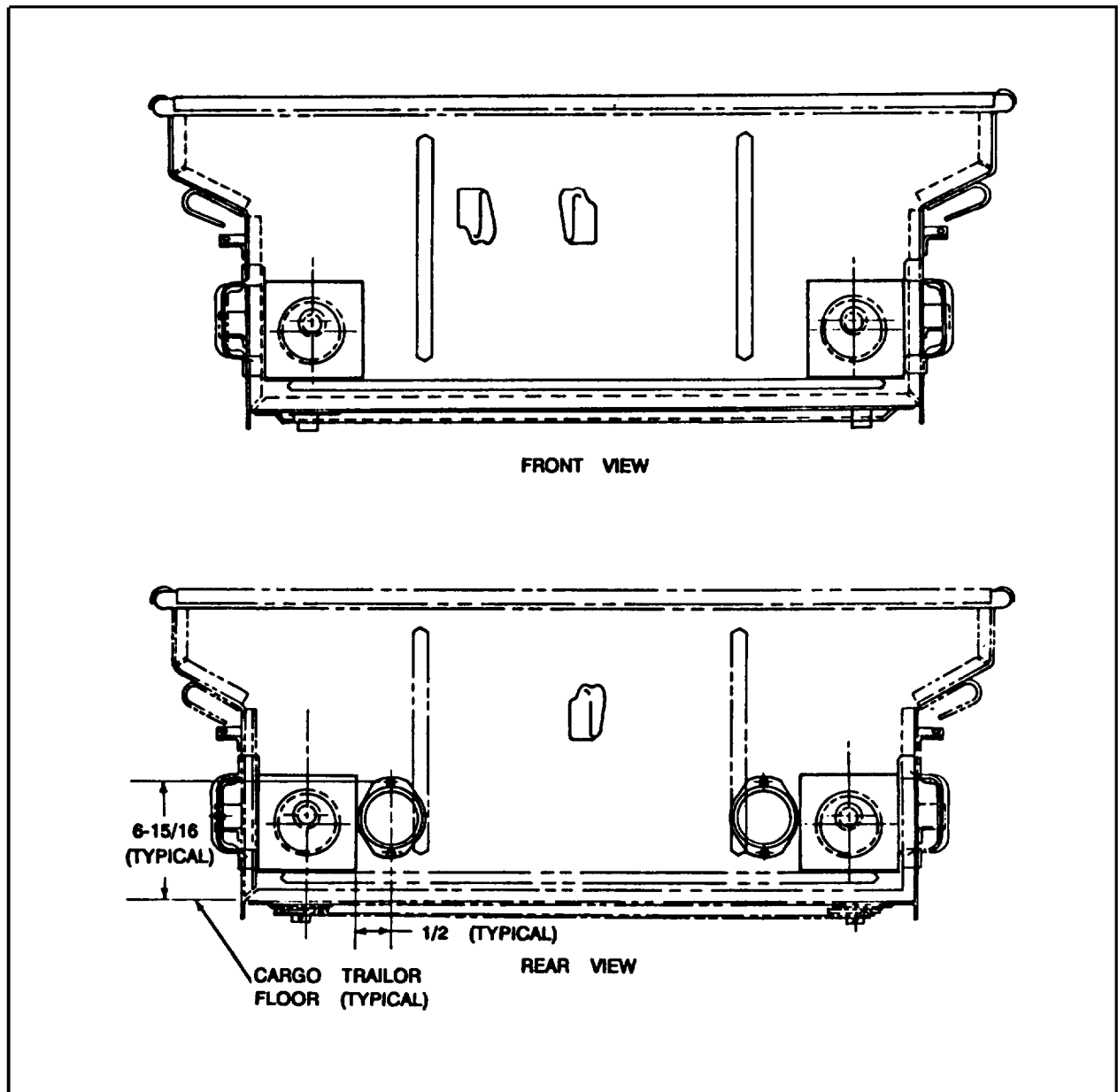

Figure 19. Anchor location and reflector mounting dimensions-front and rear panels

i. Procedure for M332 trailer.

- (1) Using template provided in kit, scribe location of four anchors each on left and right side panels (figure 20, two on front panel (figure 21), and two on gate panel (figure 22).
- (2) Using hole saw, cut out 12 anchor holes. Trim rough edge of holes.
- (3) Arc weld 12 anchors using fillet welds (figure 23, and 24).
- (4) Clean, prime, and paint in accordance with TM 43-0139.

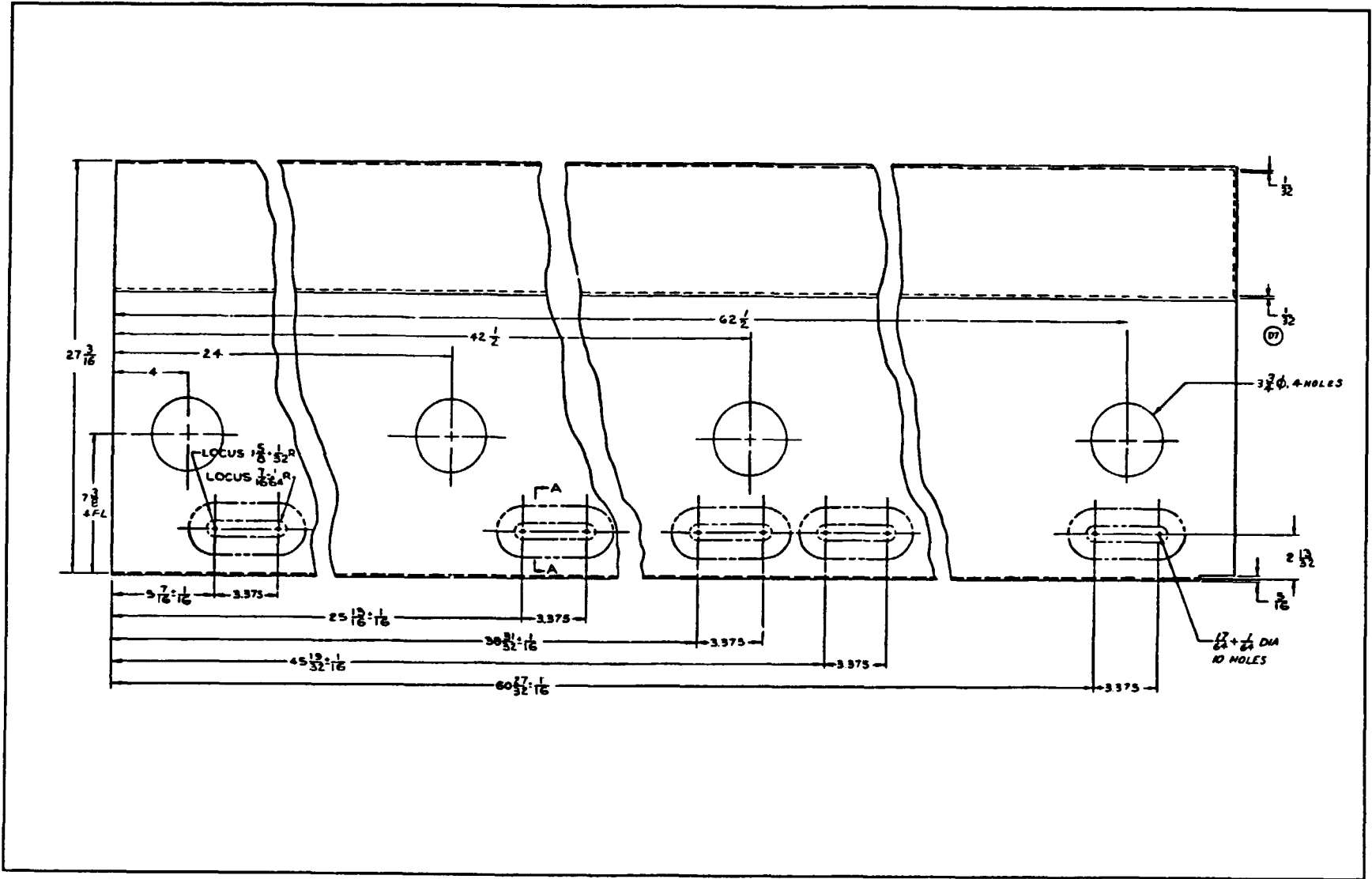

Figure 20. M332 Trailer side panel, hole locations

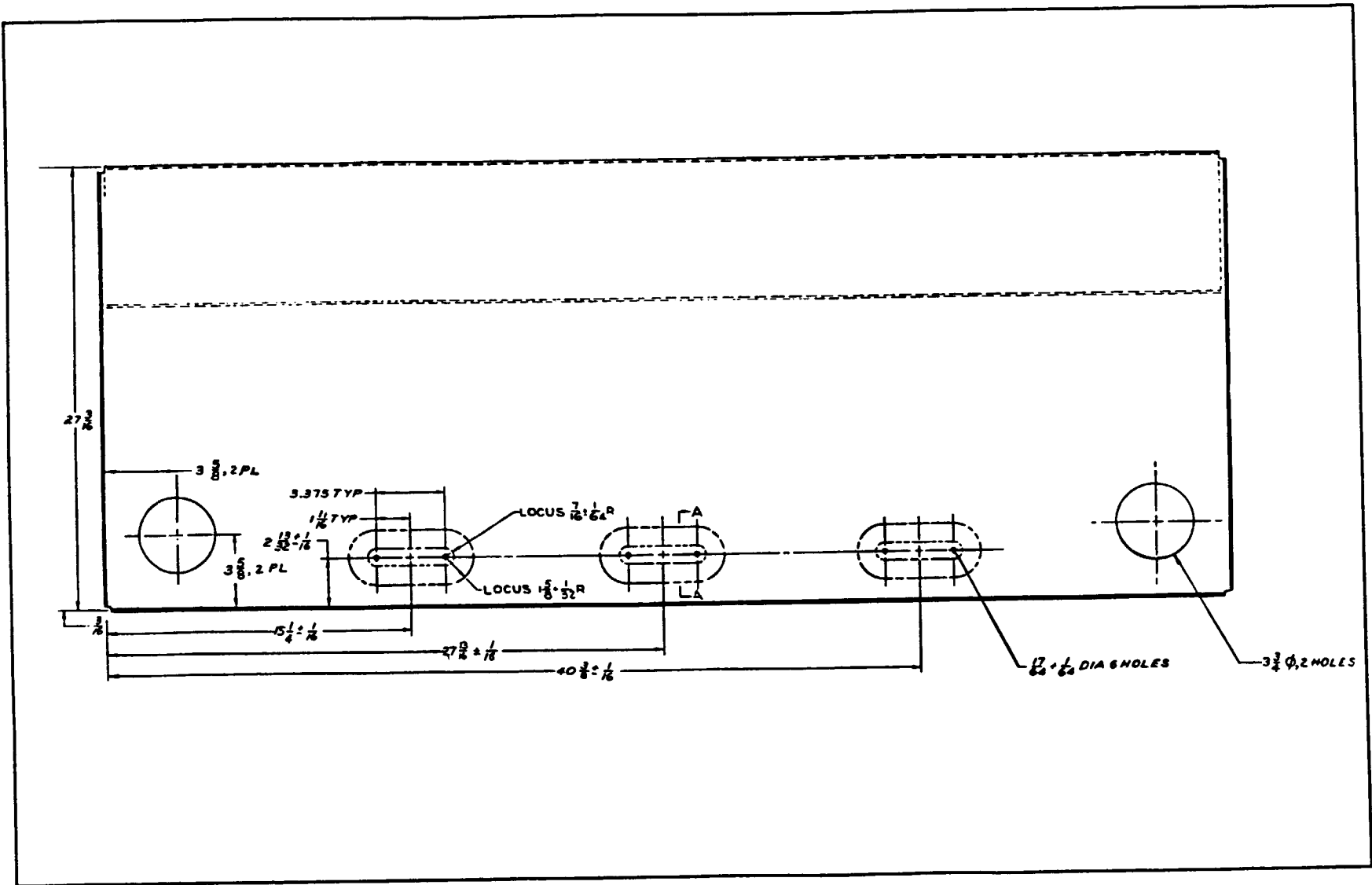

Figure 21. M332 Traller Front Panel hole locations

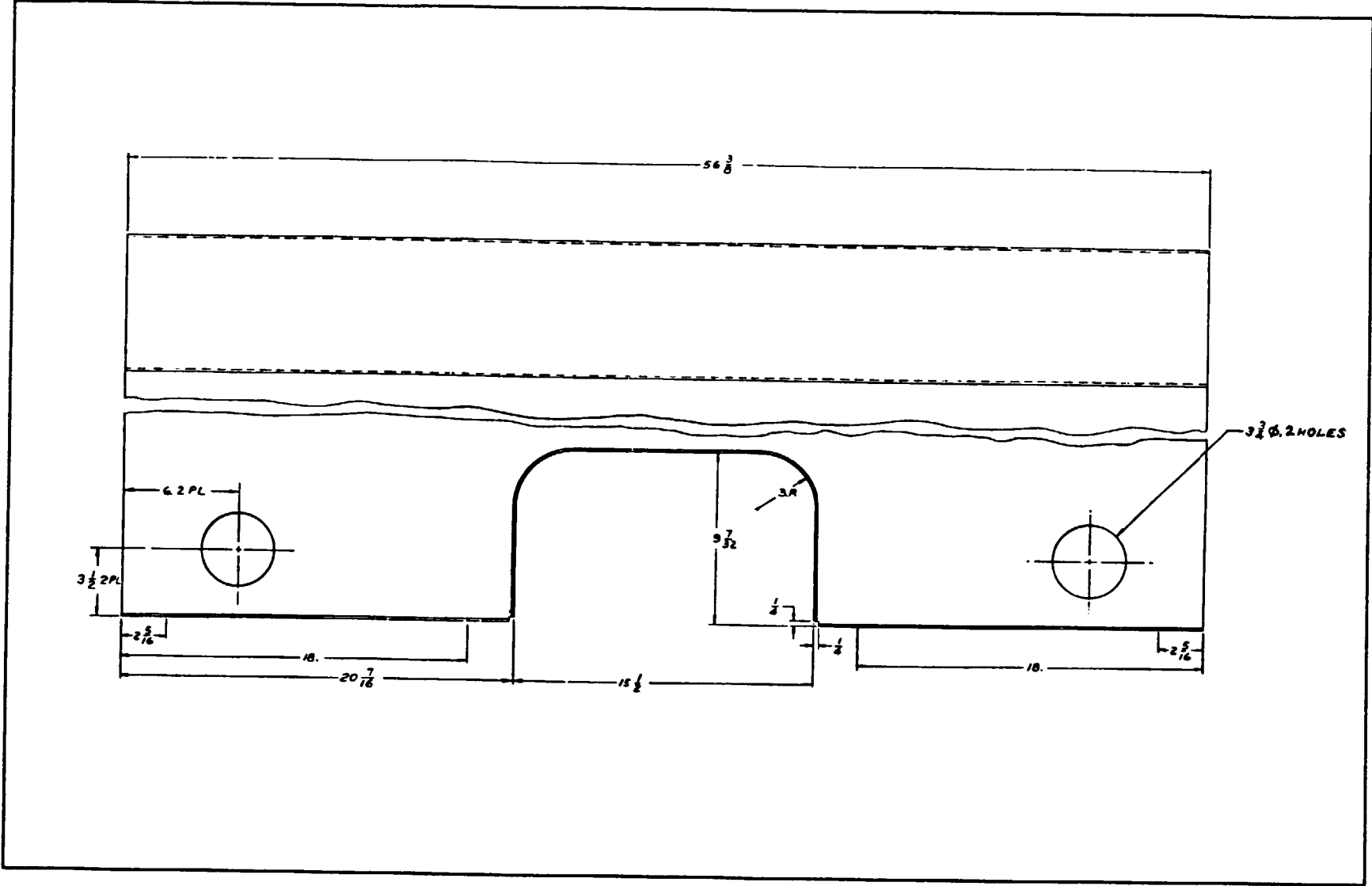

Figure 22. M332 Trailer gate panel, hole locations

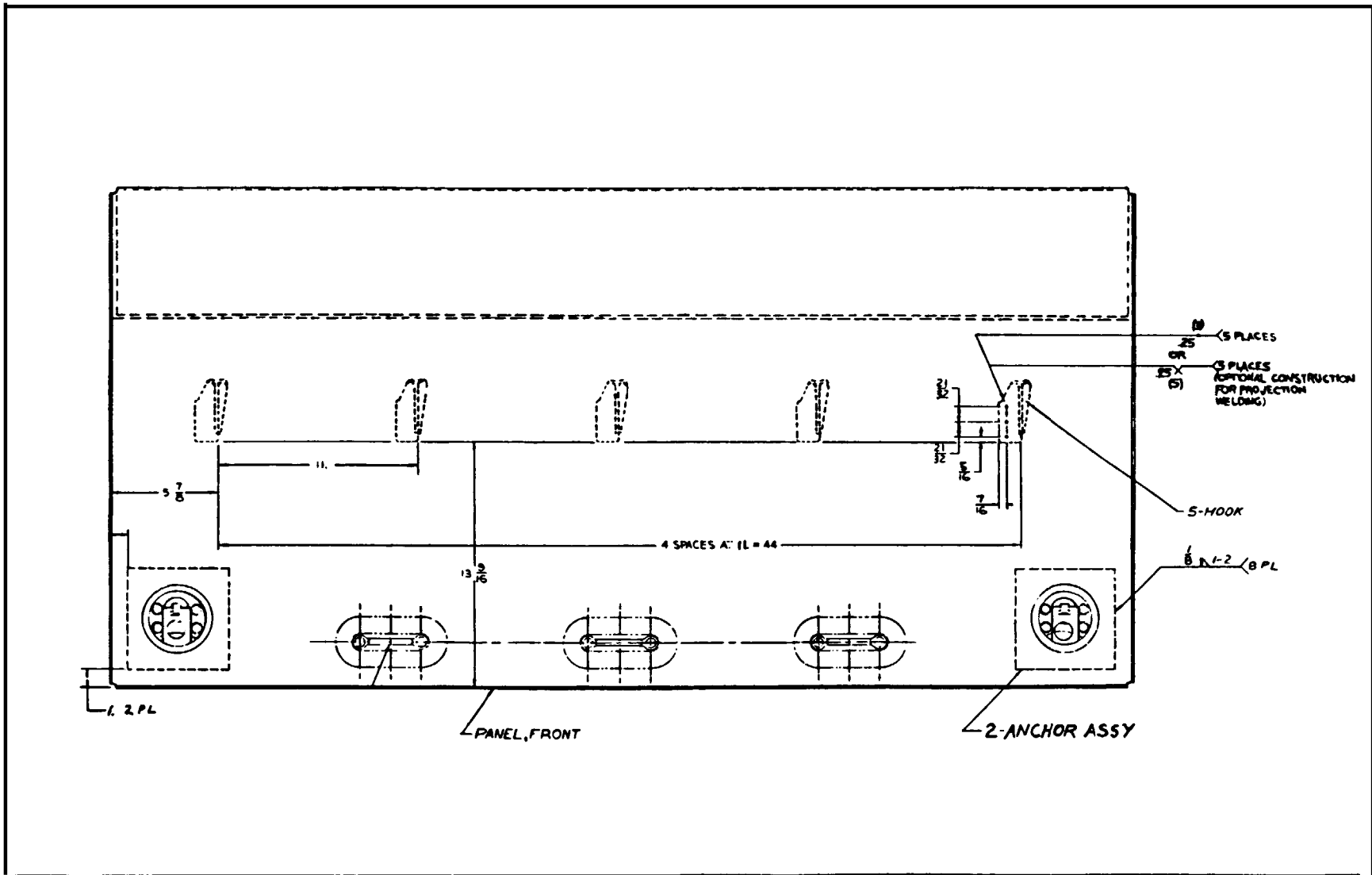

Figure 23. M332 panel assembly side

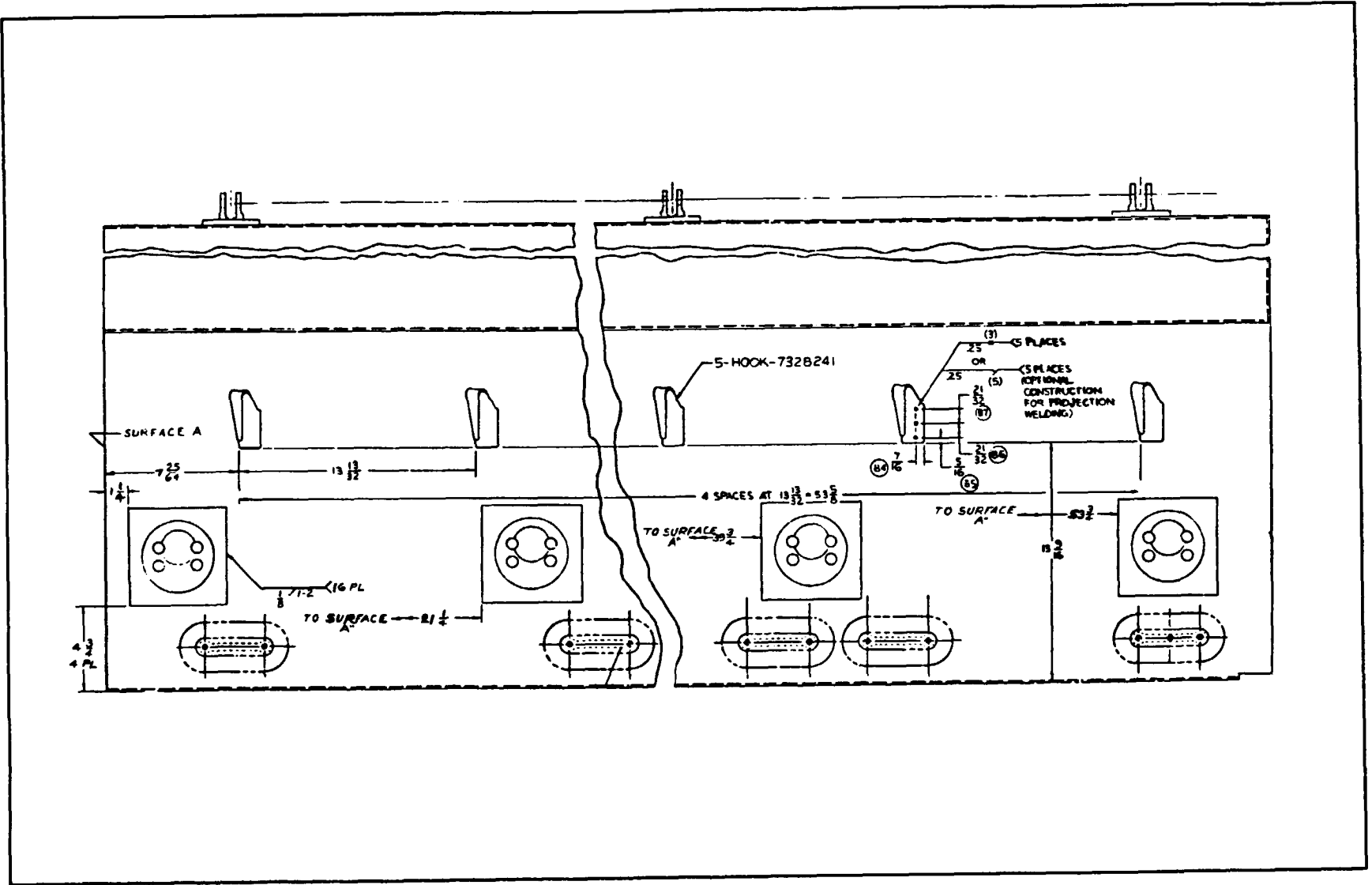

Figure 24. M332 Front panel assembly, mounting

**APPENDIX A
REFERENCES**

A-1 . SCOPE.

This appendix lists all field manuals, technical manuals, and other publications referenced in this bulletin. Also those publications that should be consulted for additional information about vehicle operations listed.

A-2 . PUBLICATION INDEX.

The following indexes should be consulted frequently for latest changes or revisions and for new publications relating to material covered in this technical bulletin.

Consolidated Index of Army Publications	DA PAM 25-30
Index of Graphic Training Aids and Devices	DA PAM 310-32

A-3. OTHER PUBLICATIONS.

1. SAFETY

First Aid for Soldiers	FM21-11
----------------------------------	---------

2. GENERAL

Welding Theory and Application	TM 9-237
Painting instructions for Army Materiel	TM 43-0139

By Order of the Secretary of the Army:

CARL E. VUONO
General, United States Army
Chief of Staff

Official:

WILLIAM J. MEEHAN II
Brigadier General United States Army
The Adjutant General

Distribution

To be distributed in accordance with DA Form 12-38, Requirements for TB 9-2300-280-30.

RECOMMENDED CHANGES TO EQUIPMENT TECHNICAL PUBLICATIONS



THEN...JOT DOWN THE DOPE ABOUT IT ON THIS FORM. CAREFULLY TEAR IT OUT, FOLD IT AND DROP IT IN THE MAIL.

SOMETHING WRONG WITH PUBLICATION

FROM: (PRINT YOUR UNIT'S COMPLETE ADDRESS)

DATE SENT

PUBLICATION NUMBER

PUBLICATION DATE

PUBLICATION TITLE

BE EXACT PIN-POINT WHERE IT IS

PAGE NO.

PARA-GRAPH

FIGURE NO.

TABLE NO.

IN THIS SPACE, TELL WHAT IS WRONG AND WHAT SHOULD BE DONE ABOUT IT.

TEAR ALONG PERFORATED LINE

PRINTED NAME, GRADE OR TITLE AND TELEPHONE NUMBER

SIGN HERE

THE METRIC SYSTEM AND EQUIVALENTS

WEIGHT MEASURE

1 Centimeter = 10 Millimeters = 0.01 Meters = 0.3937 Inches
 1 Meter = 100 Centimeters = 1000 Millimeters = 39.37 Inches
 1 Kilometer = 1000 Meters = 0.621 Miles

WEIGHTS

1 Gram = 0.001 Kilograms = 1000 Milligrams = 0.035 Ounces
 1 Kilogram = 1000 Grams = 2.2 lb.
 1 Metric Ton = 1000 Kilograms = 1 Megagram = 1.1 Short Tons

LIQUID MEASURE

1 Milliliter = 0.001 Liters = 0.0338 Fluid Ounces
 1 Liter = 1000 Milliliters = 33.82 Fluid Ounces

SQUARE MEASURE

1 Sq. Centimeter = 100 Sq. Millimeters = 0.155 Sq. Inches
 1 Sq. Meter = 10,000 Sq. Centimeters = 10.76 Sq. Feet
 1 Sq. Kilometer = 1,000,000 Sq. Meters = 0.386 Sq. Miles

CUBIC MEASURE

1 Cu. Centimeter = 1000 Cu. Millimeters = 0.06 Cu. Inches
 1 Cu. Meter = 1,000,000 Cu. Centimeters = 35.31 Cu. Feet

TEMPERATURE

$5/9(^{\circ}\text{F} - 32) = ^{\circ}\text{C}$
 212° Fahrenheit is equivalent to 100° Celsius
 90° Fahrenheit is equivalent to 32.2° Celsius
 32° Fahrenheit is equivalent to 0° Celsius
 $9/5^{\circ}\text{C} + 32 = ^{\circ}\text{F}$

APPROXIMATE CONVERSION FACTORS

TO CHANGE	TO	MULTIPLY BY
Inches	Centimeters	2.540
Feet	Meters	0.305
Yards	Meters	0.914
Miles	Kilometers	1.609
Square Inches	Square Centimeters	6.451
Square Feet	Square Meters	0.093
Square Yards	Square Meters	0.836
Square Miles	Square Kilometers	2.590
Acres	Square Hectometers	0.405
Cubic Feet	Cubic Meters	0.028
Cubic Yards	Cubic Meters	0.765
Fluid Ounces	Milliliters	29.573
its	Liters	0.473
arts	Liters	0.946
allons	Liters	3.785
Ounces	Grams	28.349
Pounds	Kilograms	0.454
Short Tons	Metric Tons	0.907
Pound-Feet	Newton-Meters	1.356
Pounds per Square Inch	Kilopascals	6.895
Miles per Gallon	Kilometers per Liter	0.425
Miles per Hour	Kilometers per Hour	1.609

TO CHANGE	TO	MULTIPLY BY
Centimeters	Inches	0.394
Meters	Feet	3.280
Meters	Yards	1.094
Kilometers	Miles	0.621
Square Centimeters	Square Inches	0.155
Square Meters	Square Feet	10.764
Square Meters	Square Yards	1.196
Square Kilometers	Square Miles	0.386
Square Hectometers	Acres	2.471
Cubic Meters	Cubic Feet	35.315
Cubic Meters	Cubic Yards	1.308
Milliliters	Fluid Ounces	0.034
Liters	Pints	2.113
Liters	Quarts	1.057
ers	Gallons	0.264
ms	Ounces	0.035
ograms	Pounds	2.205
Metric Tons	Short Tons	1.102
Newton-Meters	Pounds-Feet	0.738
Kilopascals	Pounds per Square Inch	0.145
ometers per Liter	Miles per Gallon	2.354
ometers per Hour	Miles per Hour	0.621



PIN: 010913-000